

[®]
CLASS

DS 120F-A

Drive Axle Rear Suspensions
for Ford F450 Cab Chassis
based Ambulances

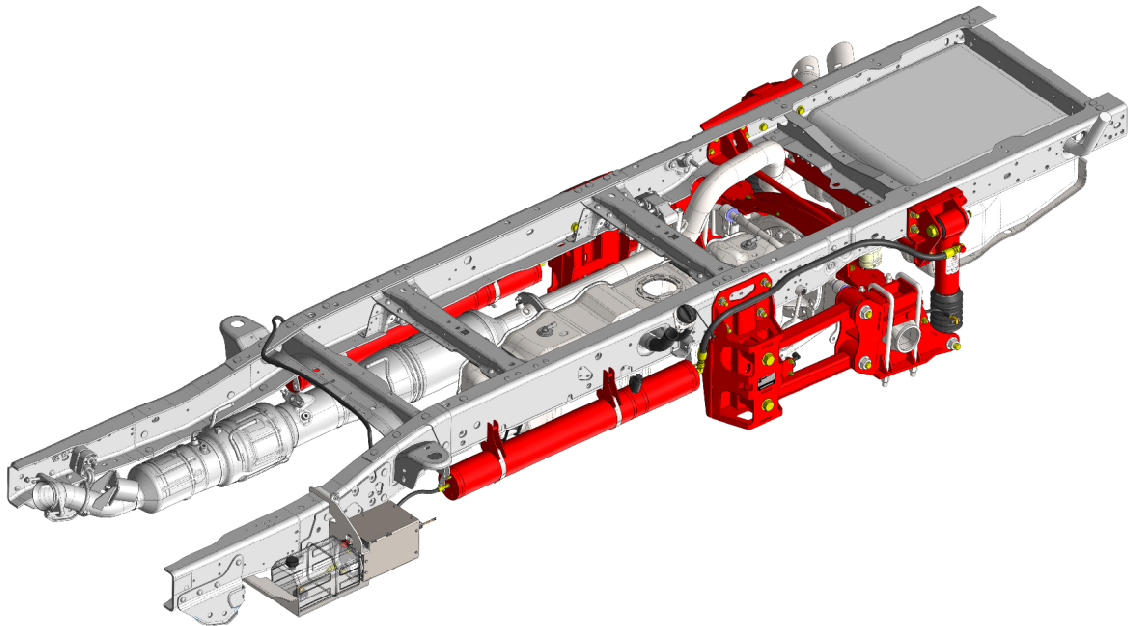

- Non-torque reactive design optimized with CLASS[®]
- Maintains proper driveline geometry through full range of torque inputs reducing driveline noise, vibration, and fatigue
- Variable stiffness and damping adjusted automatically and instantaneously based on road conditions without driver intervention
- Does not require modification to exhaust
- Compact package space claim
- 12,000 lbs GAWR for Ford F450 SuperDuty



Compressible Liquid Adaptive Suspension System

DS120F-A Drive Axle Rear Suspensions for Ford F450 Cab Chassis based Ambulances

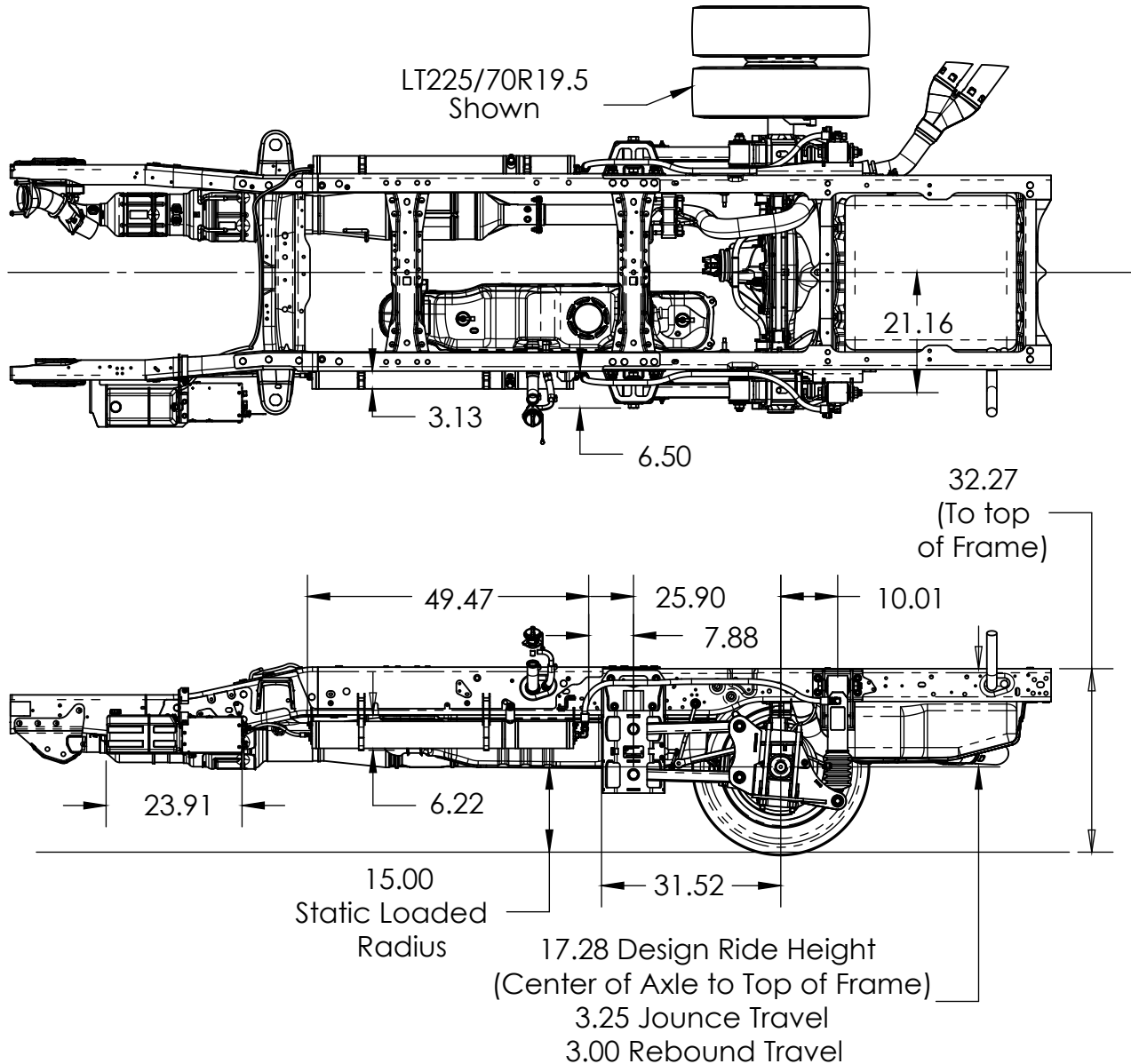

**Engineered suspension solutions for
your ride and handling issues.**



LiquidSpring™ LLC

3416 Rascal Drive
Lafayette, IN 47909

Phone: 765-474-7816

Fax: 765-474-7826

Web: www.liquidspring.com